

# Temperature/Humidity Transducer

## Indoor, Duct & Wall mounting type Temperature/Humidity transducer

### Features

- Compact design
- Built-in temp./humidity sensor
- 7 Segment LED Display (THD-DD/THD-WD)
- Various output modes  
DC4-20mA, 1-5VDC, RS485 (MODBUS RTU)
- Wide range of temp./humidity measurement  
-19.9 ~ 60.0°C / 0.0 ~ 99.9%RH
- Communication speed : 115200bps

**⚠ Please read "Caution for your safety" in operation manual before using.**

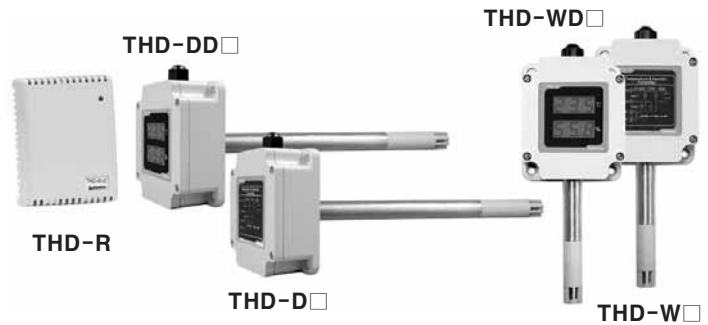

### Ordering information

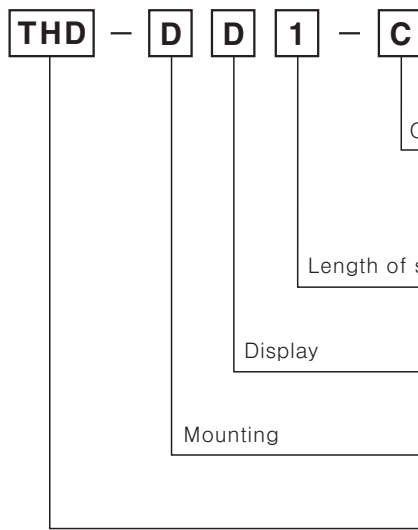

※ PT	Temperature sensor resistance value (PT100Ω)
※ PT/C	Temperature sensor resistance value (PT100Ω) / Current output (DC4-20mA)
C	Current output (DC4-20mA)
V	Voltage output (1-5VDC)
T	RS485 communication output (MODBUS RTU)
※	Built-in
1	100mm
2	200mm
	Non-Display
D	Display
R	Room (For indoor)
D	Duct mounting
W	Wall mounting
THD	Temperature Humidity Double

※ It is only for THD-R series.

### Specifications

Model	THD-R-PT	THD-R-PT/C	THD-R-□	THD-D□-□ THD-W□-□	THD-DD□-□ THD-WD□-□
Display type	_____	_____	_____	Non-indicating type	7 Segment LED Display
Digit	_____	_____	_____	_____	3Digit for temperature, humidity
Character size	_____	_____	_____	_____	10mm
Power supply	_____	_____	_____	24VDC ± 10%	_____
Power consumption	_____	_____	_____	Max. 2.4W	_____
Measuring input	Temperature (Built-in sensor)	_____	_____	Temperature, Humidity (Built-in sensor)	_____
Output	Temp.	PT100Ω resistance value	_____	●DC4-20mA ●1-5VDC ●RS485 (MODBUS RTU)	_____
	Humidity	_____	DC4-20mA		_____
Measurement range	Temp.	_____	_____	-19.9~60.0°C	_____
	Humidity	_____	_____	0.0~99.9%RH (THD-R series is required to attend for using over 90%RH.)	_____
Accuracy	Temp.	Max. ±0.8°C	_____	5.0~40.0°C Max. ±0.5°C (Max. ±1.0°C for other term)	_____
	Humidity	_____	_____	Max. ±3%RH at 30~70%RH (at 25~45°C)	

- (A) Counter
- (B) Timer
- (C) Temp. controller
- (D) Power controller
- (E) Panel meter
- (F) Tacho/Speed/Pulse meter
- (G) Display unit
- (H) Sensor controller
- (I) Switching power supply
- (J) Proximity sensor
- (K) Photo electric sensor
- (L) Pressure sensor
- (M) Rotary encoder
- (N) Stepping motor & Driver & Controller
- (O) Graphic panel
- (P) Production stoppage models & replacement

# THD Series

## Specifications

Model	THD-R-PT	THD-R-PT/C	THD-R-□	THD-D□-□ THD-W□-□	THD-DD□-□ THD-WD□-□
Sampling period	————	————	————	Fixed 0.5sec	
Insulation resistance	————	————	————	Min. 100MΩ (500VDC mega)	
Dielectric strength	————	————	————	500VAC 50/60Hz for 1 minute	
Noise strength	————	————	————	±0.3kV the square wave noise (pulse width:1μs) by the noise simulator	
Vibration	Mechanical	————	————	0.75mm amplitude at frequency of 10~55Hz in each of X, Y, Z directions for 1hour	
	Malfunction	————	————	0.5mm amplitude at frequency of 10~55Hz in each of X, Y, Z directions for 10minutes	
Shock	Mechanical	————	————	300m/s <sup>2</sup> (30G) in X, Y, Z directions for 3 times	
	Malfunction	————	————	100m/s <sup>2</sup> (10G) in X, Y, Z directions for 3 times	
Protection	IP10			IP65 (Except sensing part.)	
Ambient temperature	-20 ~ 60℃ (at non-freezing status)				
Storage temperature	-20 ~ 60℃ (at non-freezing status)				
Cable	Terminal type			4P, φ 4mm, Length:2m	
Unit weight	Approx. 55g			Approx. 160g	

\*The allowable impedance of current output is max. 600Ω

## Dimensions

- THD-R-□ ●THD-R-PT ●THD-R-PT/C

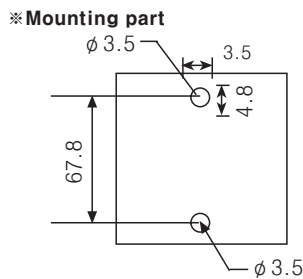
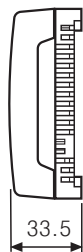
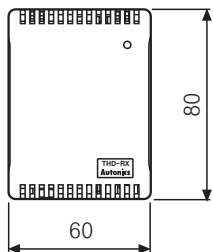

(Unit:mm)

- THD-D□-□ / THD-DD□-□ ●THD-W□-□ / THD-WD□-□

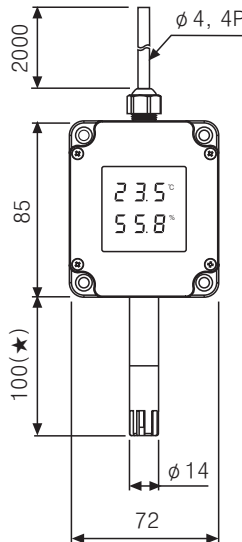
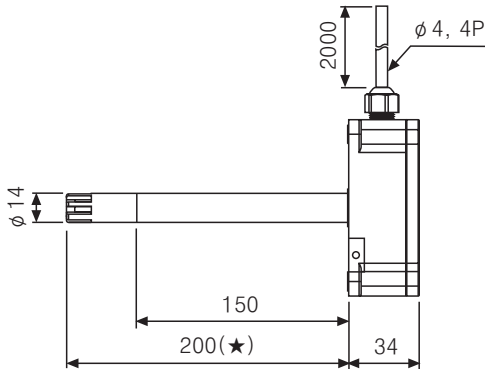

- \*Mounting part

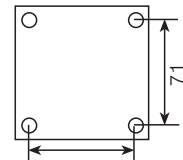

\*(★) See the ordering information to select the one with 2 sensing poles.

\*See the ordering information about display model, THD-DD□-□, THD-WD□-□.

## Connections

- THD-R Series

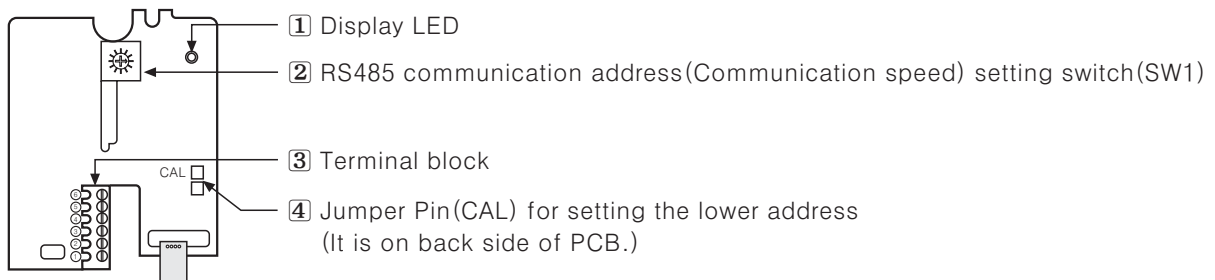

# Temperature/Humidity Transducer

## ●THD-R-PT/C

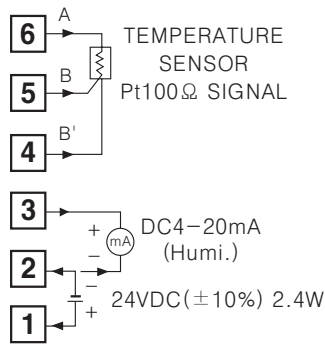

## ●THD-R-C, V, T

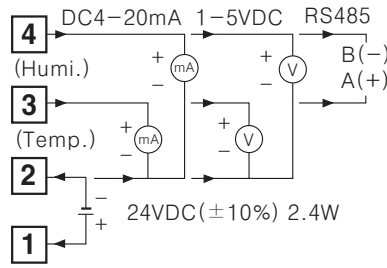

## ●THD-R-PT

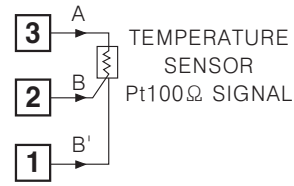

※Please note the terminal connection and be careful with power supply.

## ◎THD-D / THD-W Series

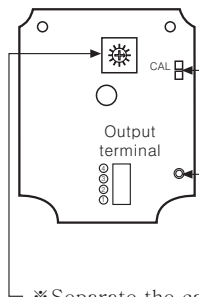

### ●Current output type

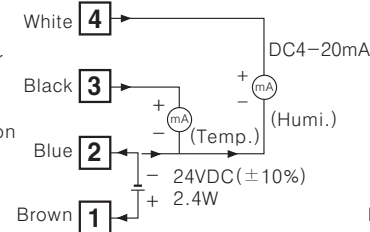

### ●Voltage output type

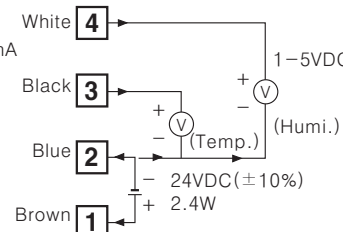

### ●Communication output type

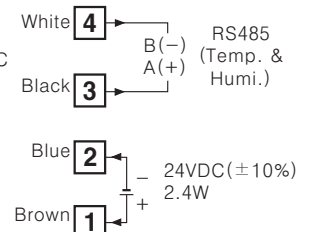

※Separate the case cover only in case of setting communication, set the unit code, communication speed using communication setting switch.

## ■Case detachment

### ●THD-R Series

Unscrew the bolt on the bottom of product and separate the case.

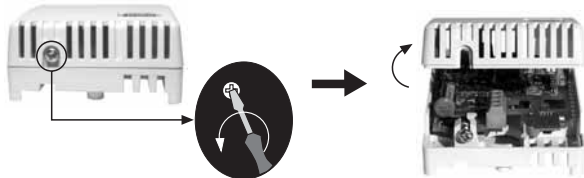

### ●THD-D / THD-W Series

Unscrew 4 bolts on the top of product and separate the case.

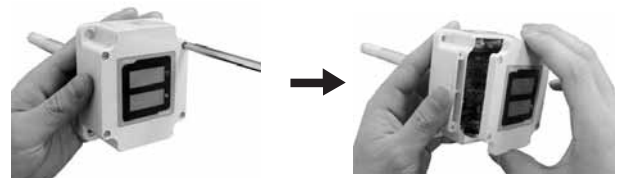

## ■Functions

### ◎Voltage output

It transmits current temperature/humidity to other equipments, PC or recorder and outputs 1-5VDC. 1VDC output represents  $-19.9^{\circ}\text{C}$  of temperature and 0.0% RH of humidity, 5VDC at  $60.0^{\circ}\text{C}$  of temperature and 99.9% RH of humidity. The temperature and humidity output are separated and the resolution is divided as 1,000.

### ◎Current output

It transmits current temperature/humidity to other equipments, PC or recorder and outputs DC4-20mA. It outputs DC4mA at  $-19.9^{\circ}\text{C}$  of temperature and 0.0%RH of humidity, DC20mA at  $60.0^{\circ}\text{C}$  of temperature and 99.9%RH of humidity. The temperature and humidity output are separated and the resolution divisible by 1,000.

### ◎Temperature sensor output(Pt 100Ω resistance value output)

It transmits current temperature/humidity to other equipments, recorder or thermometer. It outputs  $100\Omega$  at  $0^{\circ}\text{C}$  and  $119.40\Omega$  at  $50^{\circ}\text{C}$ . (TCR=3850 ppm/ $^{\circ}\text{C}$ )

(A) Counter

(B) Timer

(C) Temp. controller

(D) Power controller

(E) Panel meter

(F) Tacho/Speed/Pulse meter

(G) Display unit

(H) Sensor controller

(I) Switching power supply

(J) Proximity sensor

(K) Photo electric sensor

(L) Pressure sensor

(M) Rotary encoder

(N) Stepping motor & Driver & Controller

(O) Graphic panel

(P) Production stoppage models & replacement

# THD Series

## ◎RS485 communication output

It is used to transmit current temperature and humidity to other equipment.

### ●Interface

Standard	EIA RS485
Number of connections	31, It is available to set address 01~31
Communication method	Half Duplex
Synchronous method	Asynchronous type
Communication distance	Within max. 800m
Communication speed	1200 ~ 115200bps(Available to set)
Start bit	1bit(Fixed)
Stop bit	1bit(Fixed)
Parity bit	None(Fixed)
Data bit	8bit(Fixed)
Protocol	MODBUS RTU

※ It is not possible to change parameter related to communication of THD under the communication with high order system.

※ Match the parameter of THD communication to be same as the high order system.

※ It is not allowed to set overlapping communication address at the same communication line.

※ Please use a proper twist pair for RS485 communication.

### ●Application of system organization

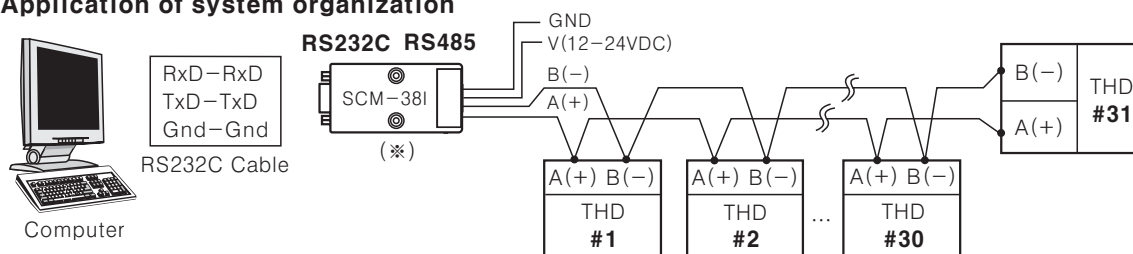

※ SCM-38I made by Autonics is recommended to use with RS232C to RS485 converter.

## ◎Communication control ordering

● The communication method is MODBUS TRU(PI-MBUS-300 REV.J).

● After 0.5sec of power supply into the high order system, it starts to communicate.

● Initial communication will be started by the high order system. When a command comes out from the high order system, THD will respond.

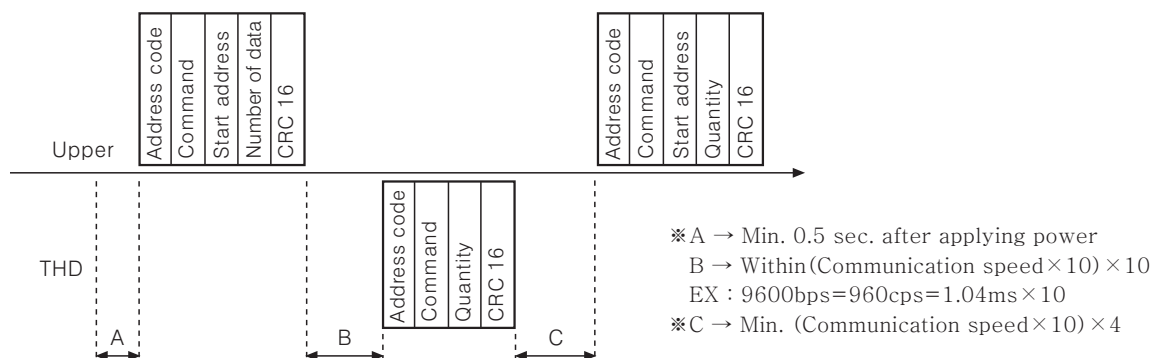

### ●Communication command and block

The format of query and response

Query

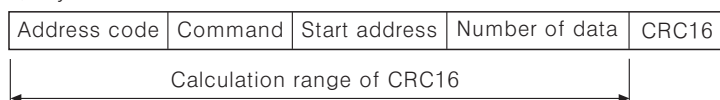

① Address code : This code which the high order system can identify THD by. It can be set within range 01H-1FH.

② Command : Read command for input register.

③ Start address : The start address of input register to read (Start address), it is available to select 0000 and 0001 for start address. 16 bit data in the address 0000 indicates temperature value, 16 bit data in the address 0001 indicates humidity value. (Refer to MODBUS Mapping table.)

④ Number of data : The number of 16 bit data from start address (No. of Points) It reads 2 of 16 bit data when start address is 0000 or reads 1 of 16 bit data is available when start address is 0001.

⑤ CRC16 : Check Sum which checks the whole frame and it is used for more reliable transmit/receive to check the error between transmitter and receiver.

# Temperature/Humidity Transducer

Response

Address code	Command	Number of data	Temperature data	Humidity data	CRC16
← Calculation range of CRC16 →					

- ①Address code : The code, W the high order system can identify THD by. It can be set within range 01H-1FH.
- ②Command : Read command for input register.
- ③Number of data : The number of 8 bit data to send from start address(No. of Bytes)  
It reads 4 of 8 bit data when start address is 0000 or reads 2 of 8 bit data is available when start address is 0001.  
(Refer to MODBUS Mapping Table)
- ④Temperature data : To get a current temperature value, divide read value by 100.  
Ex) When read data is 0x09B6, decimal value 2486, the current value is 2486/100=24.86℃.
- ⑤Humidity data : To get a current humidity value, divide read value by 100.  
Ex) When read data is 0x12FE, decimal value 4862, the current value is 4862/100=48.62%RH.
- ⑥CRC16 : Check Sum which checks the whole frame.(Refer to E-34 for CRC16 Table.)

## ●Application

(Query) : Address code(01), Start address(0000), The number of 16 Bit data to read(2) Check Sum(0x71CB)

01	04	00	00	00	02	71	CB
Unit number	Command	Start code		Amount of data		CRC16	
		High order	Low order	High order	Low order	High order	Low order

(Response) : Address code(01), The number of 8 Bit data to read(4), Temperature(0x09B6), Humidity(0x12FE)  
CRC Check sum(0x94DE)

01	04	04	09	B6	12	FE	94	DE
Unit number	Reponse command	Amount of data	Temperature data		Humidity data		CRC16	
			High order	Low order	High order	Low order	High order	Low order

## ●Error processing(Slave → Master)

1. Non-supportable command

01	81	01	81	90
Unit number	Response command	Exception code	CRC16	

※Set a received highest bit and send it to response command and exception code 01.

2. The start code of queried data is not matched to the transmittable code

01	81	02	81	90
Unit number	Response command	Exception code	CRC16	

※Set a received highest bit and send it to response command and exception code 02.

3. The number of queried data is bigger than transmittable one

01	84	03	X	X
Unit number	Response command	Exception code	CRC16	

※Set a received highest bit and send it to response command and exception code 03.

4. Abnormal processing for a received command

01	84	04	X	X
Unit number	Response command	Exception code	CRC16	

※Set a received highest bit and send it to response command and exception code 04.

## ◎Change the communication speed(THD-R Series)

- 1)Set SW1 to 0 and apply the power.
  - 2)Operation LED is flashing.
  - 3)Set a communication speed after choose SW1 within the range 1~8 and hold it for 3sec.
  - 4)After set a communication speed, LED will be ON.
- ※Factory default communication speed is 9600bps(SW 1:4) for communication speed.  
 ※In order to change the communication speed, please turn off the power and repeat step 1) ~ 4).  
 ※Setting table of communication speed (bps).

SW1	Communication speed(BPS)
1	1200
2	2400
3	4800
4	9600
5	19200
6	38400
7	57600
8	115200

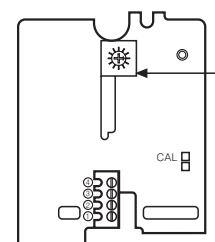

<Inner PCB of THD-R>

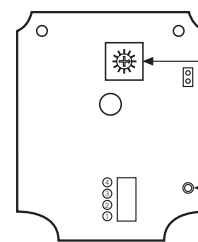

<Inner PCB of THD-D□, THD-W□>

(A) Counter

(B) Timer

(C) Temp. controller

(D) Power controller

(E) Panel meter

(F) Tacho/Speed/Pulse meter

(G) Display unit

(H) Sensor controller

(I) Switching power supply

(J) Proximity sensor

(K) Photo electric sensor

(L) Pressure sensor

(M) Rotary encoder

(N) Stepping motor & Driver & Controller

(O) Graphic panel

(P) Production stoppage models & replacement

# THD Series

## ◎Change the communication address(THD-R Series)

- 1) Set CAL Jump pin and SW1 at new address, apply the power.
- 2) The communication address is changed automatically.

※Factory default communication address is 01. (SW1 : 1, CAL Jump pin : Open)

※In order to change the communication address, please turn off the power and repeat step 1)~2).

※Setting table of communication address

CAL Pin	SW1	Add no.	CAL Pin	SW1	Add no.
OPEN	1	01	SHORT	0	16
OPEN	2	02	SHORT	1	17
OPEN	3	03	SHORT	2	18
OPEN	4	04	SHORT	3	19
OPEN	5	05	SHORT	4	20
OPEN	6	06	SHORT	5	21
OPEN	7	07	SHORT	6	22
OPEN	8	08	SHORT	7	23
OPEN	9	09	SHORT	8	24
OPEN	A	10	SHORT	9	25
OPEN	B	11	SHORT	A	26
OPEN	C	12	SHORT	B	27
OPEN	D	13	SHORT	C	28
OPEN	E	14	SHORT	D	29
OPEN	F	15	SHORT	E	30
-	-	-	SHORT	F	31

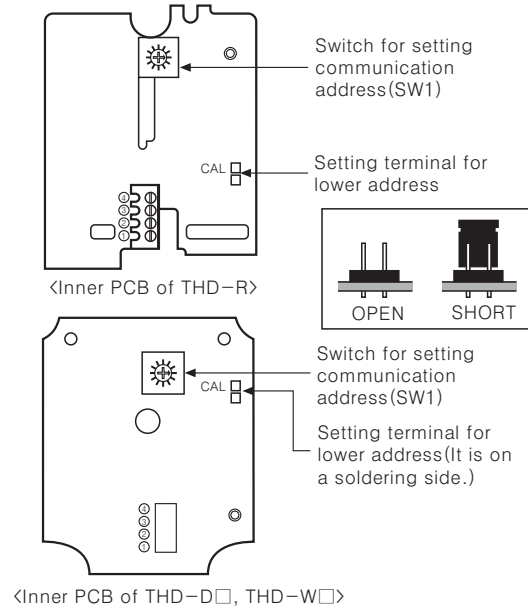

## ■Caution for using

1. After checking the input specification, terminal polarity, connect the wires correctly.
2. Do not connect a wire, examine and repair when the power is applying.
3. Do not touch the temperature/humidity sensor module.
4. Please use THD-R series as wall mounting type.
5. Caution for cleaning
  - ①Use dry towel
  - ②Do not use acid, chrome acid and solvent but alcohol.
  - ③Clean after turn off the power and turn it on 30 min. after.
6. Be sure that metal dust and wire-dregs are not flowed in the unit.
7. Connect the wires after checking polarity.
8. Please use separated line from high voltage line or power line in order to avoid inductive noise.
9. Keep away from the high frequency instruments. (High frequency welding machine & sewing machine, big capacitive SCR controller)
10. The switch or circuit breaker should be installed near by user for convenience.
11. Installation environment
  - ①It shall be used indoor
  - ②Altitude Max. 2000m
  - ③Pollution Degree 2
  - ④Installation Category II